

|x|

|x|

|x|

|xx|

3mm x 3/8-inch Foam Back Up
For Servo Wire Cut Out
(As Required)

1/8-inch Plywood Dihedral
Brace

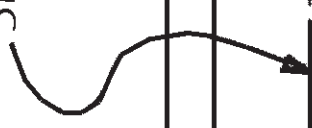

X

X

X

R1 A (4) Cut To
Fit Dihedral Brace



R1 A (TYP)
Extend Dihedral Brace



R1 B (TYP)



Cut Out For Aileron Servo
Wires



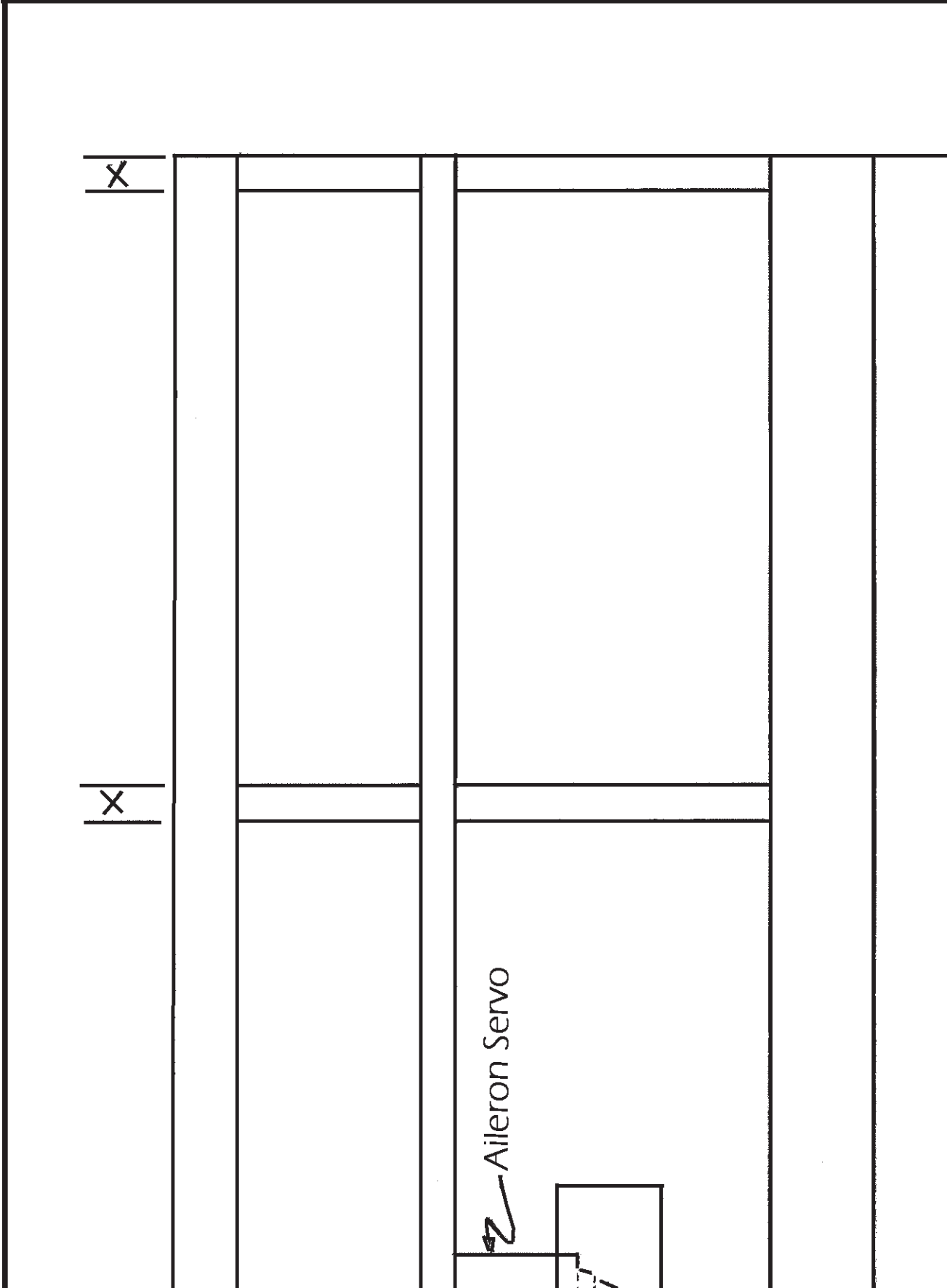

Locate Approx As Sho

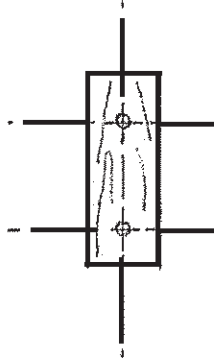
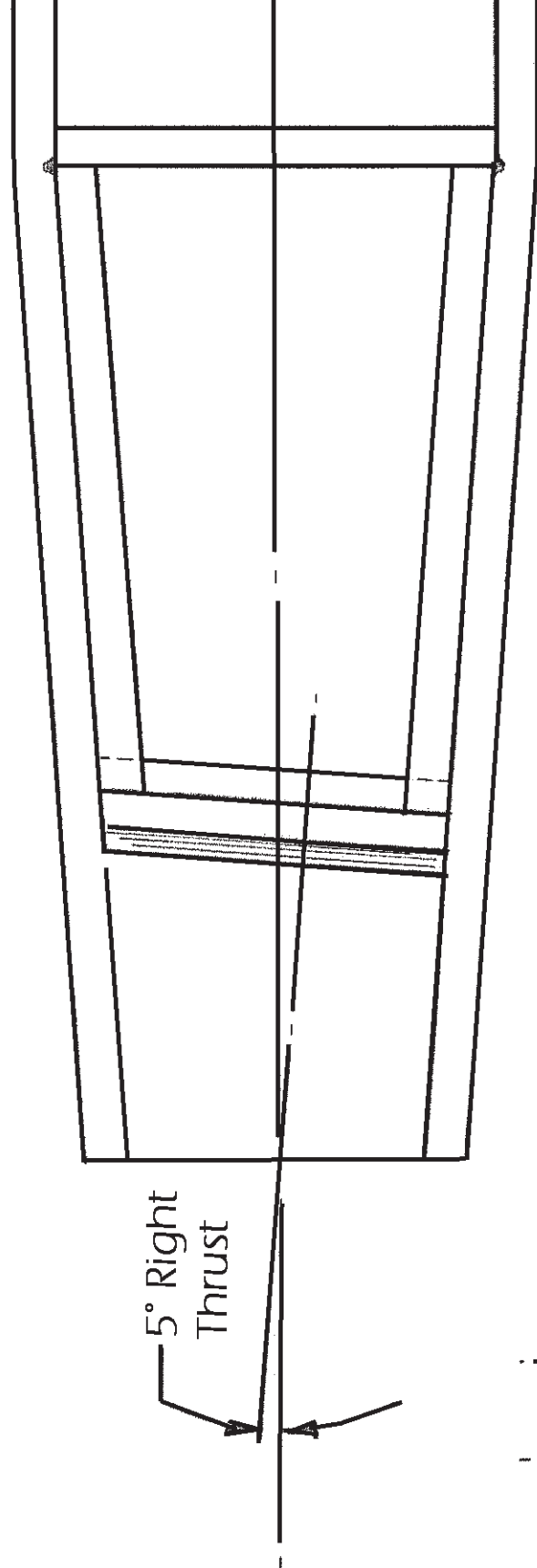
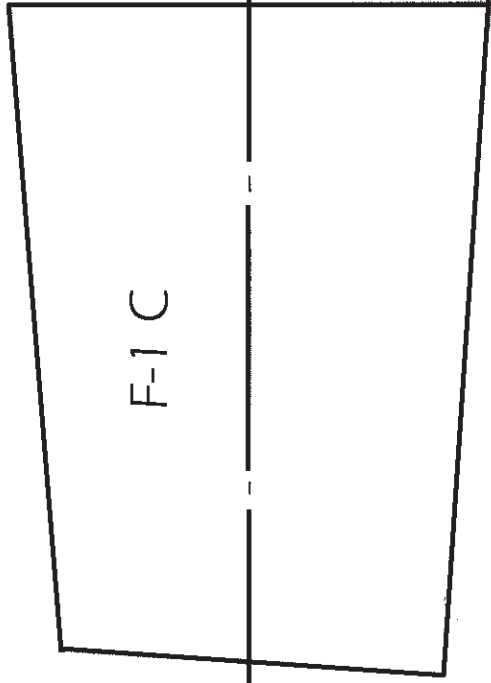

1/8-inch Ply



WN

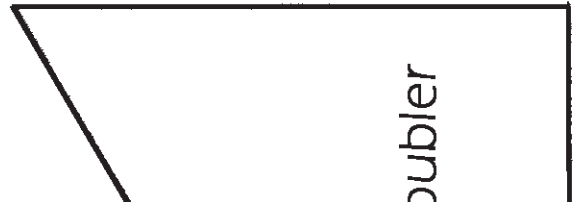

Doubler

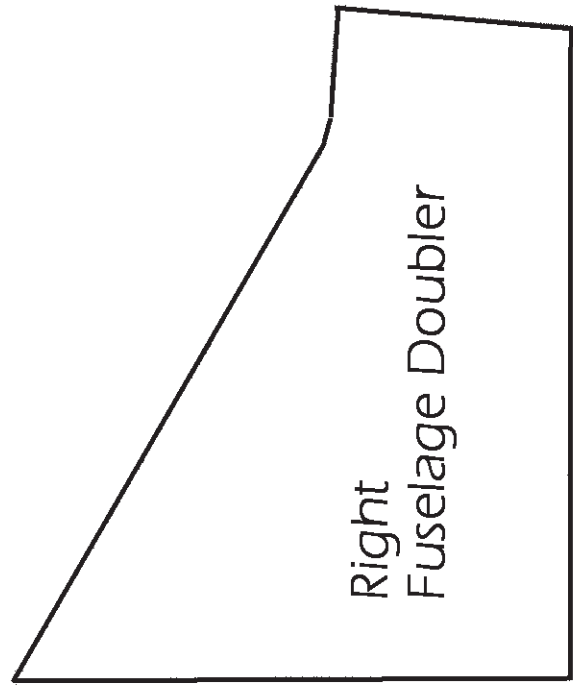

Right
Fuselage Doubler



Wing Di

Shorten Rib F
1/8-inch Dihedral Bra
(Four Ribs)

Fuselage Scribe Line
Location (Four Places)

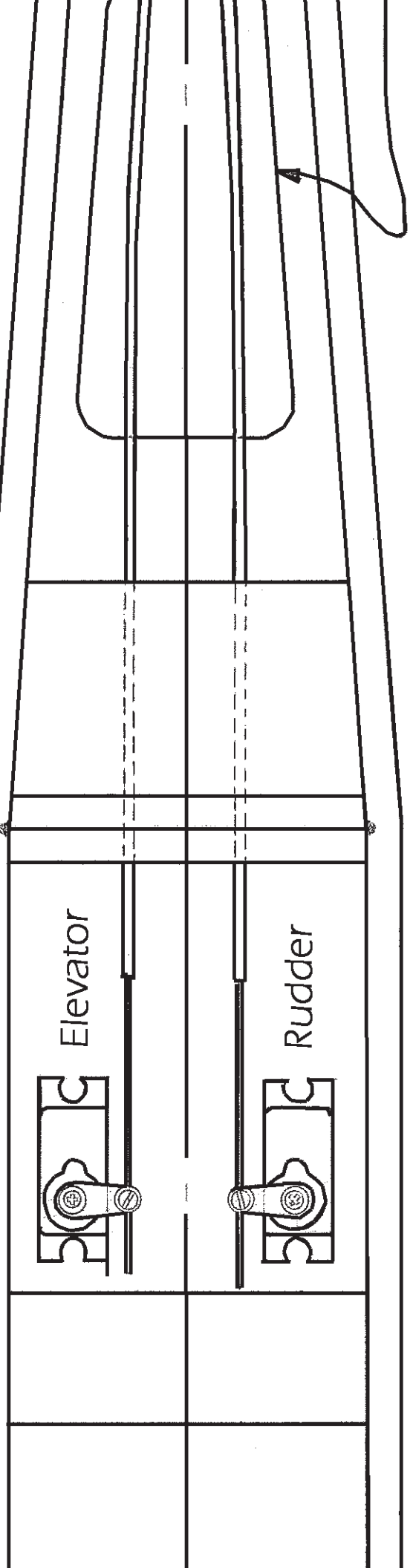

Elevator

Rudder

1-11/16 inch



headral



R-1 A
(12 Required)

Cut Out For
Servo Wires (Eight Ribs)



R-1 B
(12 Required)

- Cooling Air Outlet
(Bottom Sheeting Only)

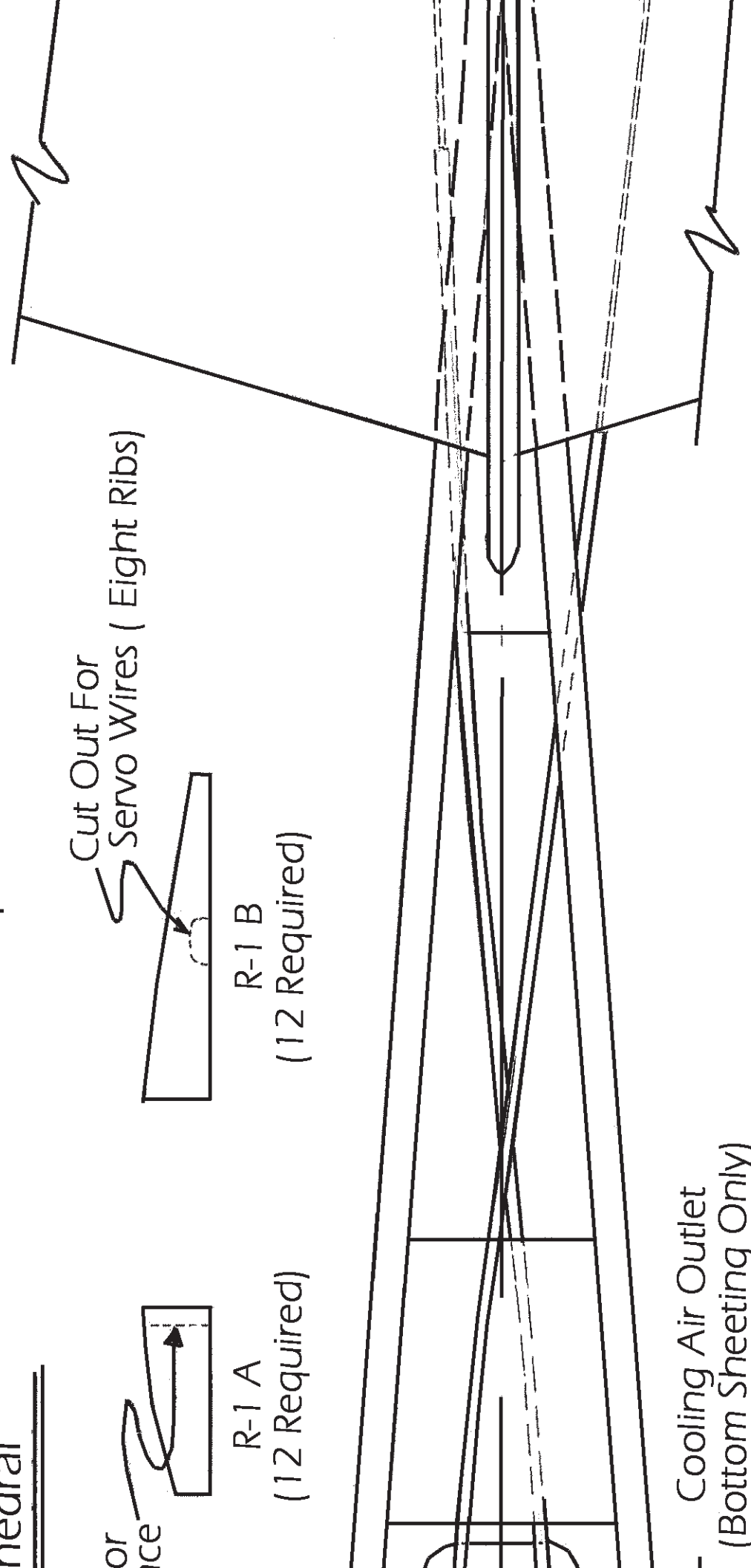



Dihedral Brace 1/8-inch Ply

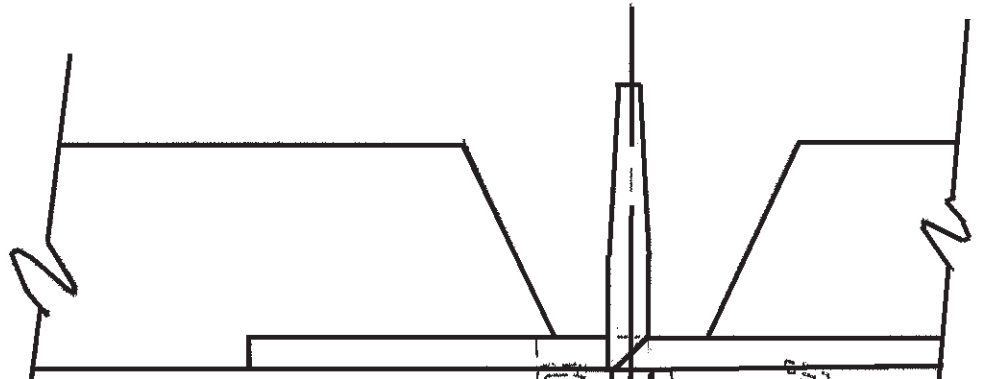

Servo Cutouts
As Required

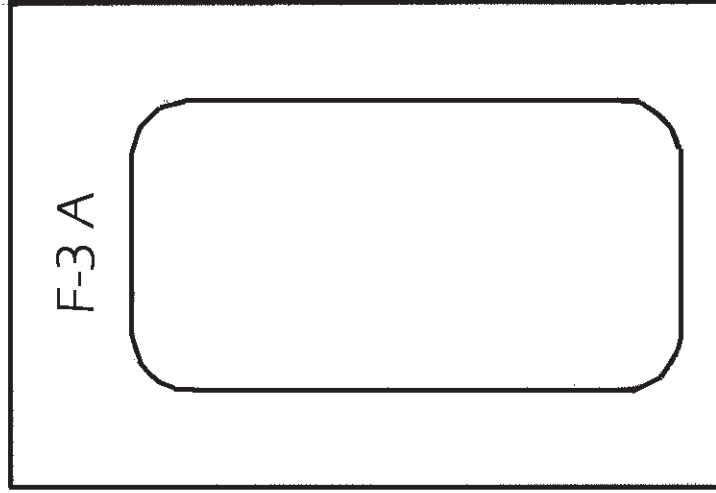
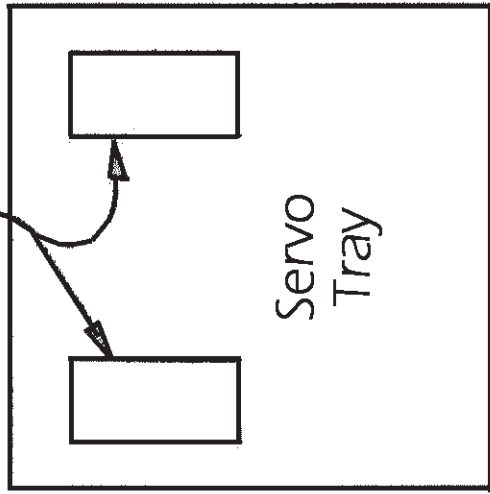

1/16-inch Ply
Cut Groove
Flap Connector Parts

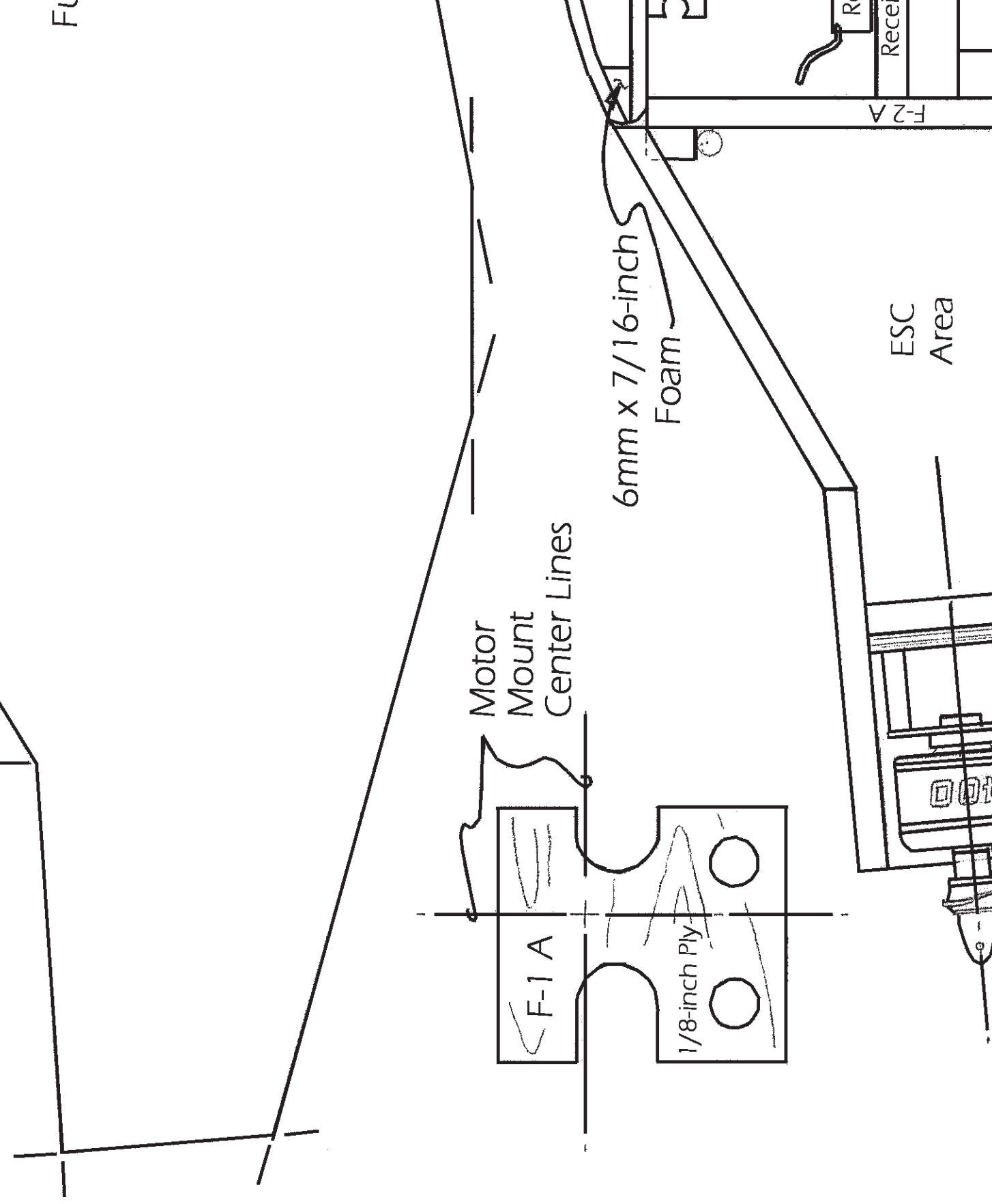



Balsa Template
(Two required)

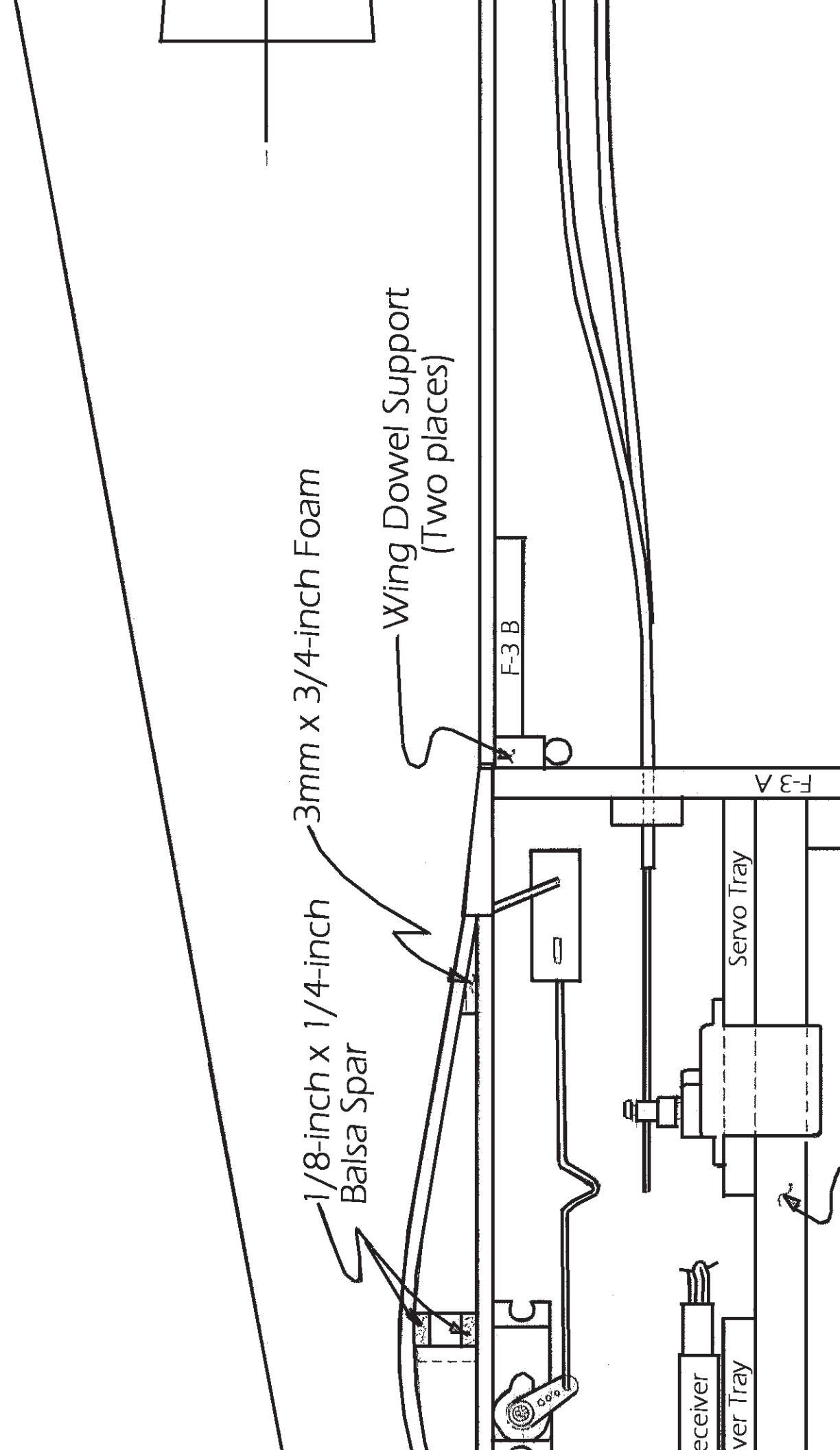

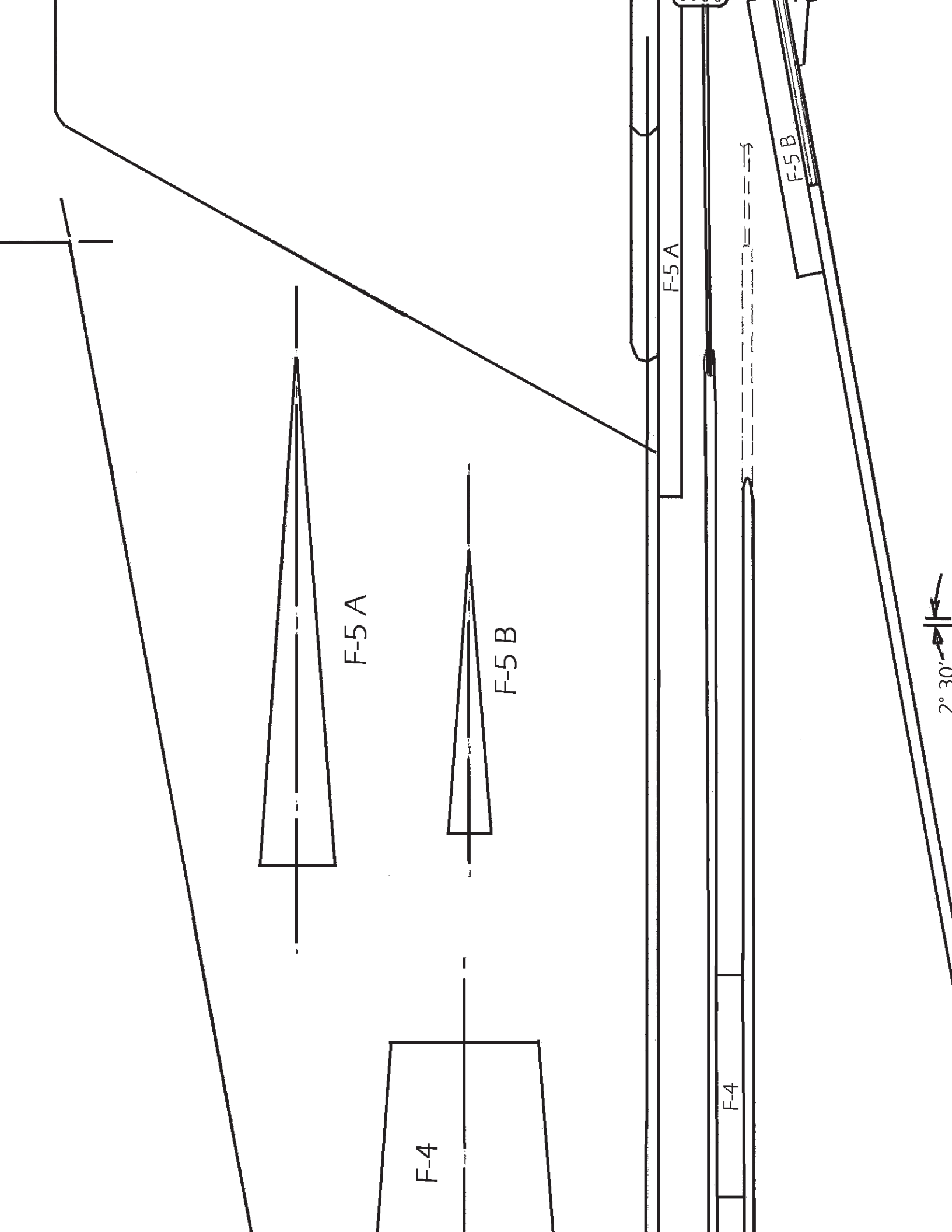

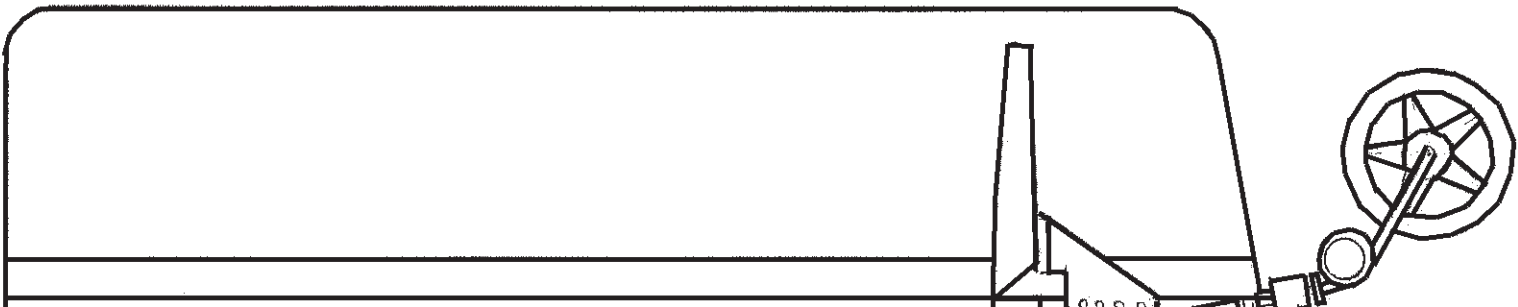
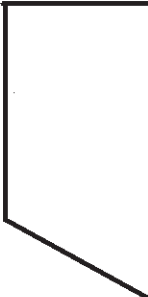
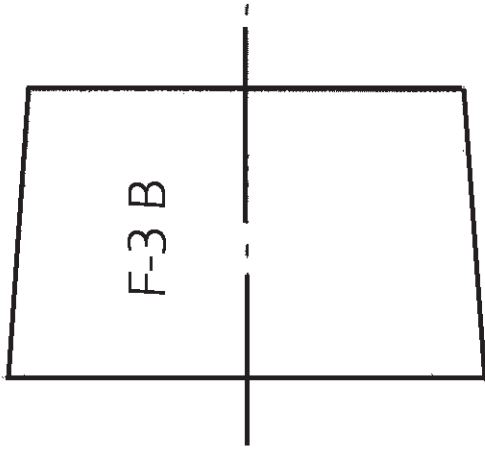
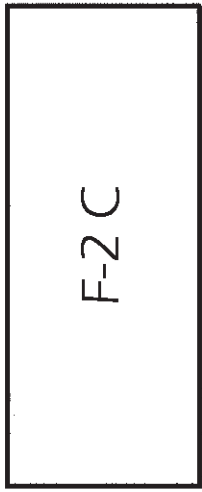
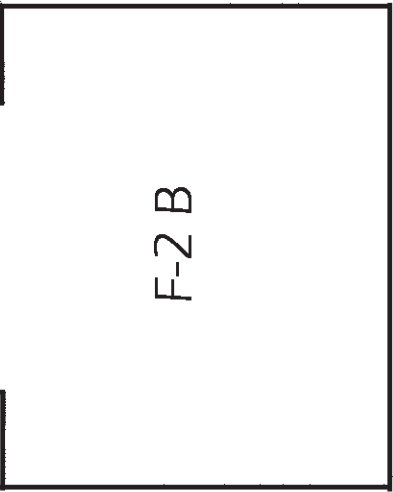
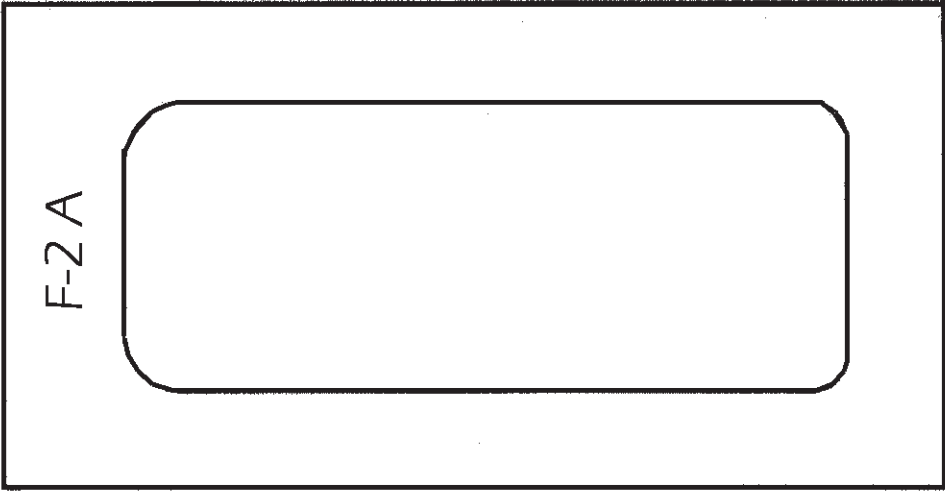

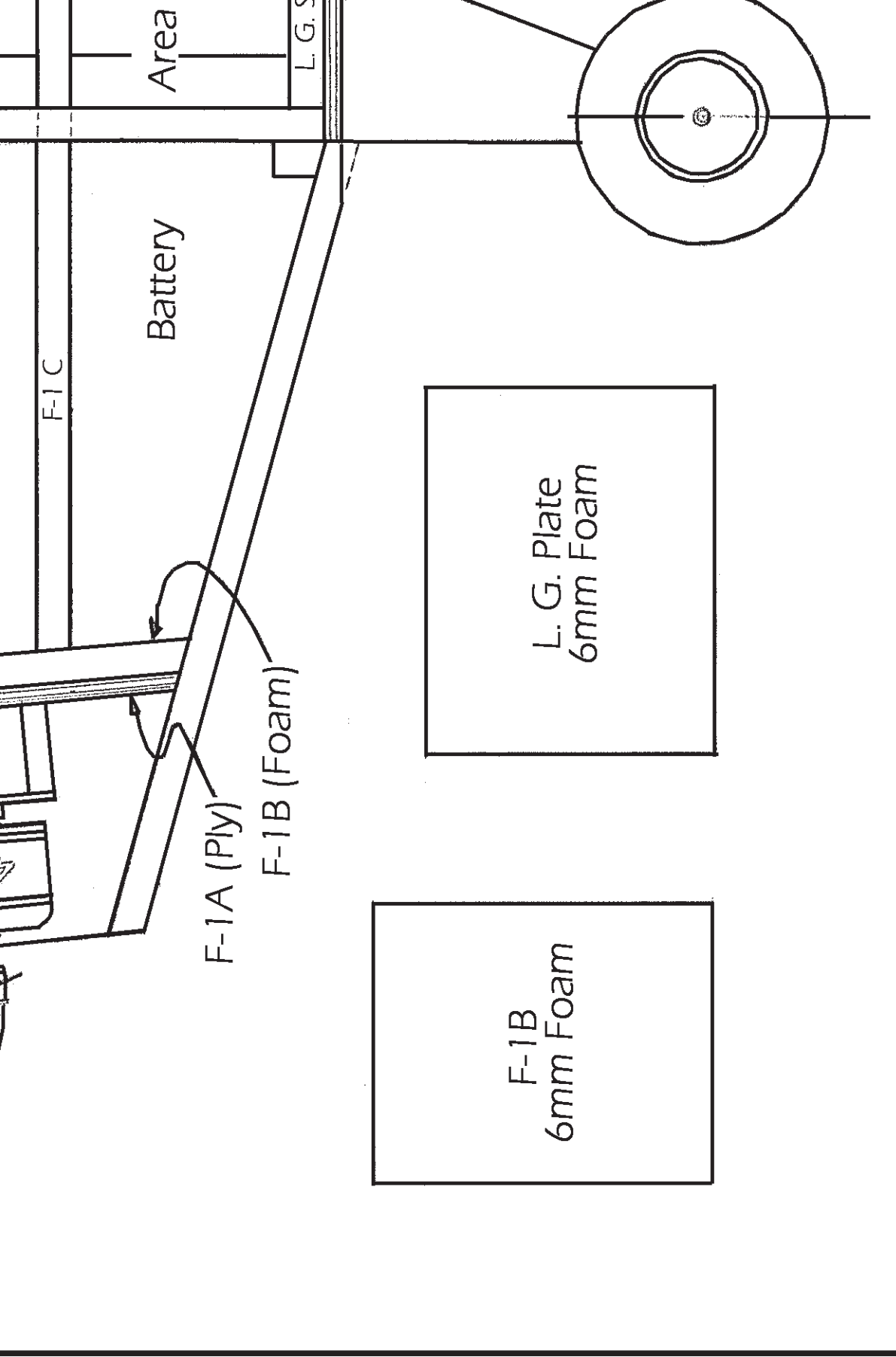

F-2 B

F-2 C

Support

6mm x 3/8 inch
Tray Support (A/R)

Landing Gear
Plate 1/8-inch Ply

Elevator

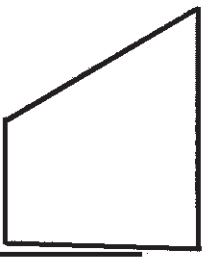

Center Rib
Angle Gage



Tail Wheel Plate
1/8-inch Ply

Horizontal
Stab

Mark But Do
Not Cut

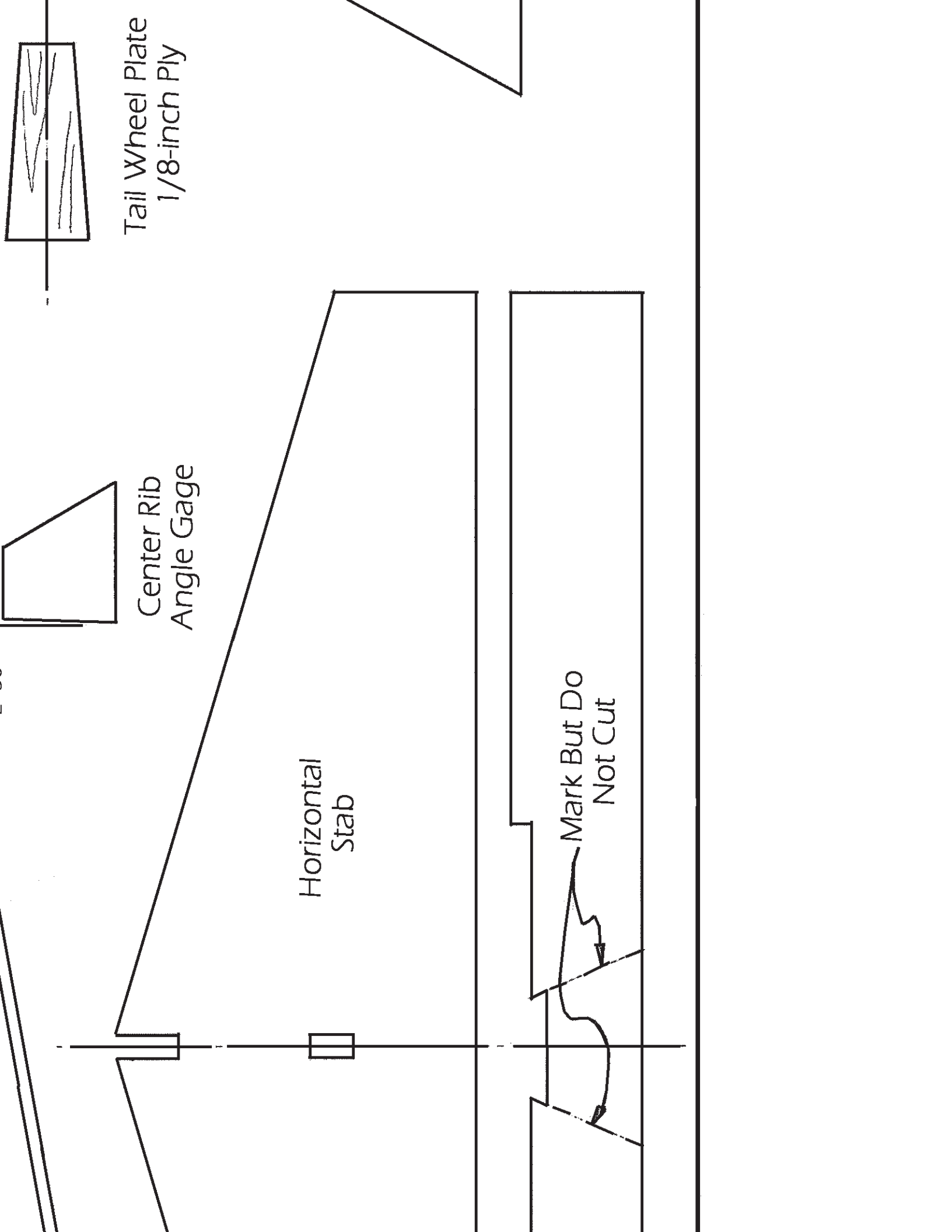

Coyote E Parkflyer

WINGSPAN: $38\frac{3}{4}$ inches WING AREA: 237 square inches

4 or 5 CHANNELS (FLAPS OPTIONAL)

DESIGNED AND DRAWN BY MIKE HAUSNER

mikehausner@aol.com

